



# ArkCam Basic D-Class



Ark Vision Systems



## ArkCam Basic D-Class

Die Ethernet-Kamera "ArkCam Basic D-Class" ist der perfekte Allrounder zum Überwachen von Gefahrenbereichen und Arbeitsprozessen. Die Kamera ist der ideale Sensor, um Bilder in Echtzeit in bestehende Bordcomputersysteme zu integrieren.

Durch die hohe optische Auflösung gepaart mit Optionen, wie zum Beispiel das Einblenden von Overlays, ist sie die Basis bzw. Erweiterung für nahezu alle Anwendungsfelder. Robustheit gegen Erschütterungen, Kälte, Hitze und Nässe versterhen sich von selbst.

The Ethernet camera "ArkCam Basic D-Class" is the perfect all-rounder for monitoring hazardous areas and work processes in rugged, mobile or stationary applications. It is the ideal sensor for integrating images into existing systems in real-time.

Due to its high optical resolution paired with options such as the fade-in of overlays, it is the basis or extension for almost all fields of application. Robustness against vibrations, cold, heat and wetness are basic characteristics of our cameras.

### Key Facts

- FullHD-Auflösung 2 Megapixel
  - Konfiguration über WebGUI
  - Videoausgabeformat H.264
  - Erweiterter Temperaturbereich von -40°C bis +85°C
  - Hohe mechanische Belastbarkeit bis zu 100 g
  - Hochdruckreiniger geeignet nach IP69K
  - Integrierte Beleuchtung IR oder Weißlicht (optional)
- FullHD-resolution 2 Megapixel
  - Configuration via WebGUI
  - Video output format H.264
  - Extended temperature range from -40°C up to +85°C
  - High mechanical load capacity up to 100 g
  - High pressure cleaner resistant according to IP69K
  - Integrated illumination IR or white light (optional)

### Steckverbindung

### Connector

#### Power und Signale

- Steckertyp M12A-kodiert Stecker 8polig

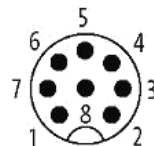

#### Power supply and signals

- Connector type M12A-coded Male 8pole

#### Datensignale

- Steckertyp M12D-kodiert Buchse 4polig

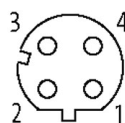

#### Datasignals

- Connector type M12D-coded Female 4pole

Technische Daten	Technical specifications
<p><b>Sensor</b></p> <ul style="list-style-type: none"> <li>▪ Auflösung 1920 x 1080 (2MP)</li> <li>▪ CMOS Bildsensor 1/2.7" / HDR</li> <li>▪ Bildwiederholrate 30 (FPS)</li> </ul> <p><b>Spannungsversorgung</b></p> <ul style="list-style-type: none"> <li>▪ 9-32V DC</li> <li>▪ Leistungsaufnahme &lt; 13 W</li> </ul> <p><b>Bildwinkel (horizontal)</b></p> <ul style="list-style-type: none"> <li>▪ 45°, 60°, 90° &amp; 125°</li> </ul> <p><b>Betriebstemperaturbereich</b></p> <ul style="list-style-type: none"> <li>▪ -40°C bis +85°C</li> </ul> <p><b>Lagertemperaturbereich</b></p> <ul style="list-style-type: none"> <li>▪ -40°C bis +85°C</li> </ul> <p><b>EMV Belastbarkeit / Zulassung</b></p> <ul style="list-style-type: none"> <li>▪ Zulassungen gemäß allen relevanten EMV-Richtlinien aus den Bereichen Industrie, Landmaschinen, Stapler und Baumaschinen. Zertifikate auf Anfrage erhältlich.</li> </ul> <p><b>Mechanische Belastbarkeit</b></p> <ul style="list-style-type: none"> <li>▪ Stoß- und Vibrationsfest für den Einsatz in den Bereichen Landmaschinen, Stapler und Baumaschinen. Zertifikate auf Anfrage erhältlich.</li> </ul> <p><b>Schutzklassen</b></p> <ul style="list-style-type: none"> <li>▪ IP68 Schutz gegen dauerndes Untertauchen.</li> <li>▪ IP69K Schutz gegen Wasser bei Hochdruck-/Dampfstrahlreinigung.</li> <li>▪ Zertifikate auf Anfrage erhältlich.</li> </ul> <p><b>Schnittstellen</b></p> <ul style="list-style-type: none"> <li>▪ Ethernet 100BASE-TX</li> </ul> <p><b>Steckverbindung</b></p> <ul style="list-style-type: none"> <li>▪ M12/D</li> <li>▪ M12/A</li> </ul> <p><b>Beleuchtung( optional)</b></p> <ul style="list-style-type: none"> <li>▪ 850nm IR oder weißlicht LED</li> </ul> <p><b>Frontscheibe</b></p> <ul style="list-style-type: none"> <li>▪ Speziell entspiegelt und gehärtet</li> <li>▪ Scheibenheizung</li> </ul> <p><b>Gehäuse</b></p> <ul style="list-style-type: none"> <li>▪ Aluminium eloxiert</li> </ul> <p><b>Protokoll</b></p> <ul style="list-style-type: none"> <li>▪ RTP/RTSP, TCP/UDP</li> </ul> <p><b>Video-Ausgabeformat</b></p> <ul style="list-style-type: none"> <li>▪ H.264</li> </ul> <p><b>Software</b></p> <ul style="list-style-type: none"> <li>▪ Konfiguration über WebGUI</li> </ul> <p><b>Gewicht</b></p> <ul style="list-style-type: none"> <li>▪ 0,57kg</li> </ul>	<p><b>Sensor</b></p> <ul style="list-style-type: none"> <li>▪ resolution 1920 x 1080 (2MP)</li> <li>▪ CMOS image sensor 1/2.7" / HDR</li> <li>▪ frames per second 30 (FPS)</li> </ul> <p><b>Power supply</b></p> <ul style="list-style-type: none"> <li>▪ 9-32V DC</li> <li>▪ power consumption &lt; 13 W</li> </ul> <p><b>Viewing Angles (horizontal)</b></p> <ul style="list-style-type: none"> <li>▪ 45°, 60°, 90° &amp; 125°</li> </ul> <p><b>Operating temperature</b></p> <ul style="list-style-type: none"> <li>▪ -40°C up to +85°C</li> </ul> <p><b>Storage temperature</b></p> <ul style="list-style-type: none"> <li>▪ -40°C up to +85°C</li> </ul> <p><b>Electromagnetic compatibility (EMC)</b></p> <ul style="list-style-type: none"> <li>▪ Approvals in accordance with all relevant EMC guidelines from the areas of industry, agricultural machinery, forklifts and construction machinery. Certificates available on request.</li> </ul> <p><b>Mechanical load capacity</b></p> <ul style="list-style-type: none"> <li>▪ Shock and vibration resistant for use in the areas of agricultural machinery, forklifts and construction machinery. Certificates available on request.</li> </ul> <p><b>Protection classes</b></p> <ul style="list-style-type: none"> <li>▪ IP68 protection against permanent immersion.</li> <li>▪ IP69K protection against water during high pressure / steam jet cleaning.</li> <li>▪ Certificates available on request.</li> </ul> <p><b>Interface</b></p> <ul style="list-style-type: none"> <li>▪ Ethernet 100BASE-TX</li> </ul> <p><b>Connector</b></p> <ul style="list-style-type: none"> <li>▪ M12/D</li> <li>▪ M12/A</li> </ul> <p><b>Integrated illumination (optional)</b></p> <ul style="list-style-type: none"> <li>▪ 850nm IR or white light LED</li> </ul> <p><b>Front glass</b></p> <ul style="list-style-type: none"> <li>▪ specially hardened &amp; anti-reflective</li> <li>▪ glass heating</li> </ul> <p><b>Housing</b></p> <ul style="list-style-type: none"> <li>▪ aluminum anodized</li> </ul> <p><b>Protocol</b></p> <ul style="list-style-type: none"> <li>▪ RTP/RTSP, TCP/UDP</li> </ul> <p><b>Output format</b></p> <ul style="list-style-type: none"> <li>▪ H.264</li> </ul> <p><b>Software</b></p> <ul style="list-style-type: none"> <li>▪ Configuration via WebGUI</li> </ul> <p><b>Weight</b></p> <ul style="list-style-type: none"> <li>▪ 0,57kg</li> </ul>

## Maße / Dimensions



85,00

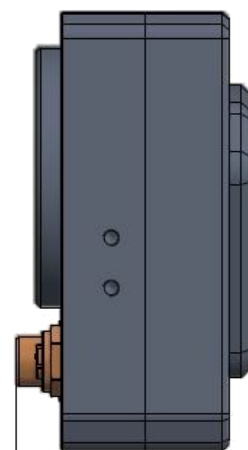

56,50

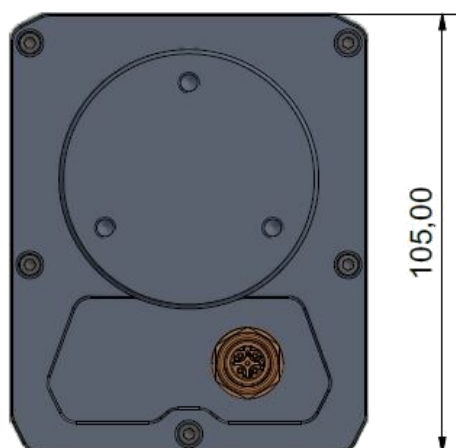

105,00

Maße in / Dimensions in mm